

REINHOLD ENVIRONMENTAL Ltd.



2011 APC Round Table & Expo Presentation

July 11-12, 2011, in Cleveland, OH / Hosted by FirstEnergy

All presentations posted on this website are copyrighted by Reinhold Environmental, Ltd (RE). Any unauthorized downloading, attempts to modify or to incorporate into other presentations, link to other websites, or obtain copies for any other uses than the training of attendees to RE's Conferences is expressly prohibited, unless approved in writing by RE or the original presenter. RE does not assume any liability for the accuracy or contents of any materials contained in this library which were presented and/or created by persons who were not employees of RE.



Aging ESPs – How To Improve Performance

PCUG Round Table- Cleveland Ohio
July 11, 2011

Gerry Klemm and Mike Nelson
Southern Company
Copyright Southern Company 2011

Why Do We Need to Improve Performance?

- To Restore Performance Degradation Due to:
 - Fuel Changes
 - Aging Effects: Corrosion, Misalignment, Ineffective rapping, Inoperative Auxiliary Equipment
- Visibility Issues (Required to perform better than permit requirements)
- EGU MACT (Preliminary)
 - 0.03 lb/MBtu Total, 30 day average with PM CEMS, No exceptions for start up, shut down or malfunction

What are the Options for Improvement?

- Power Sectionalization
- Rapping Sectionalization
- Repowering
- Rebuilding / Converting
- Flow Improvement
- Gas Conditioning
- Collecting Area Expansion

Power Sectionalization

- Splitting Bus Sections
- Adding T-Rs

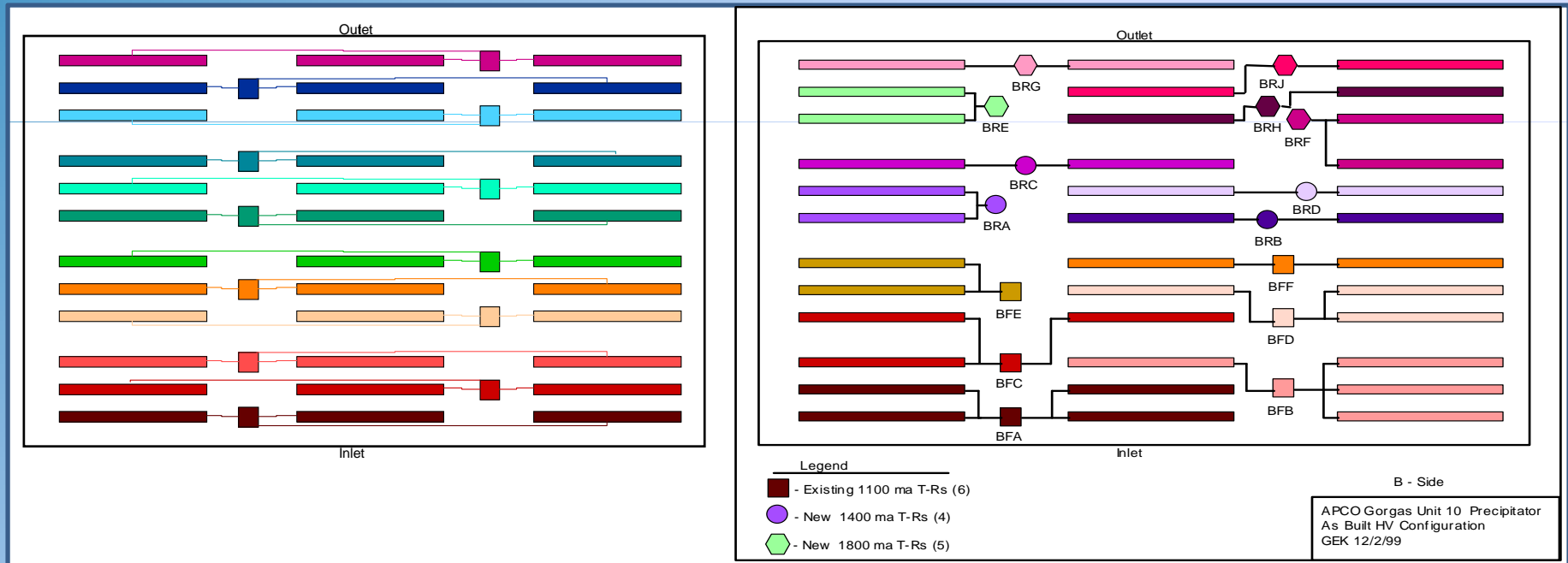

Original Sectionalization

After Re-sectionaling and adding T-Rs

Rapping Sectionalization

- Adding Rappers Across Gas Flow
- Adding Rappers With Gas Flow

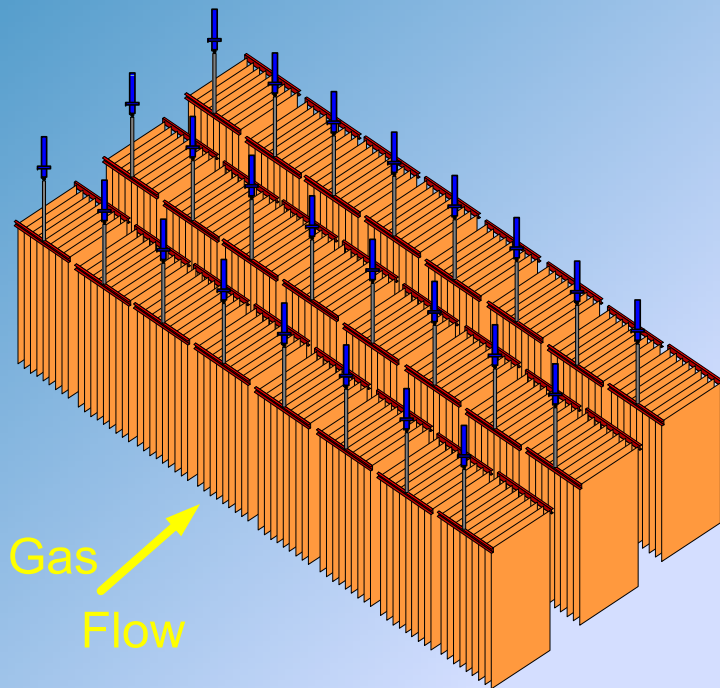

Leading Edge Rapping Only

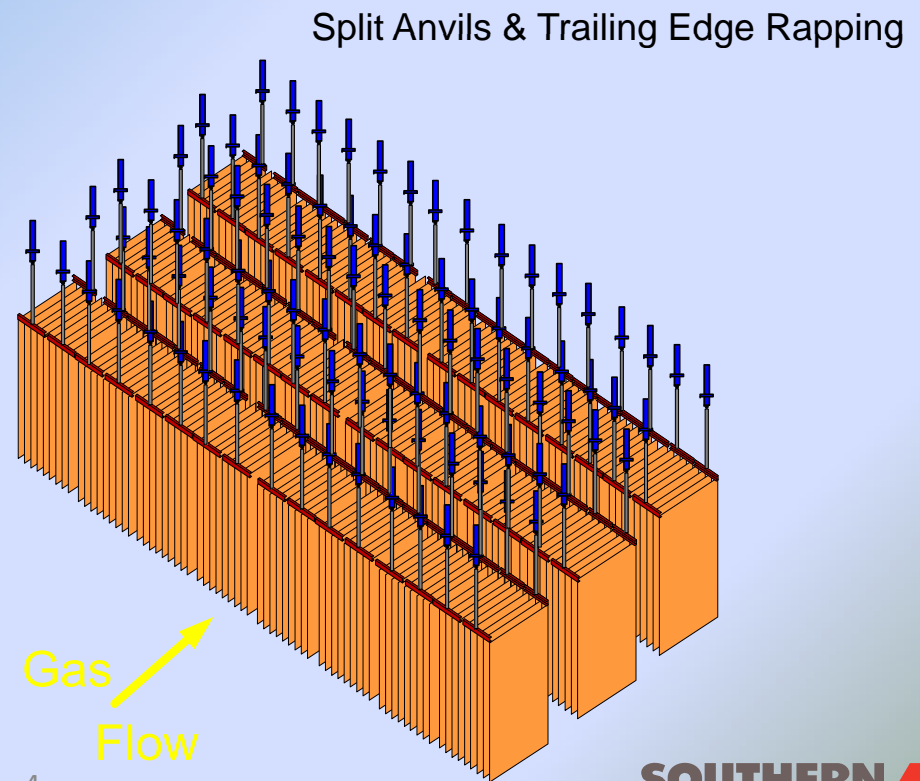

Repowering

- Adding / Converting to Switched Mode Power Supplies
- Adding/ Converting to Medium Frequency Control systems

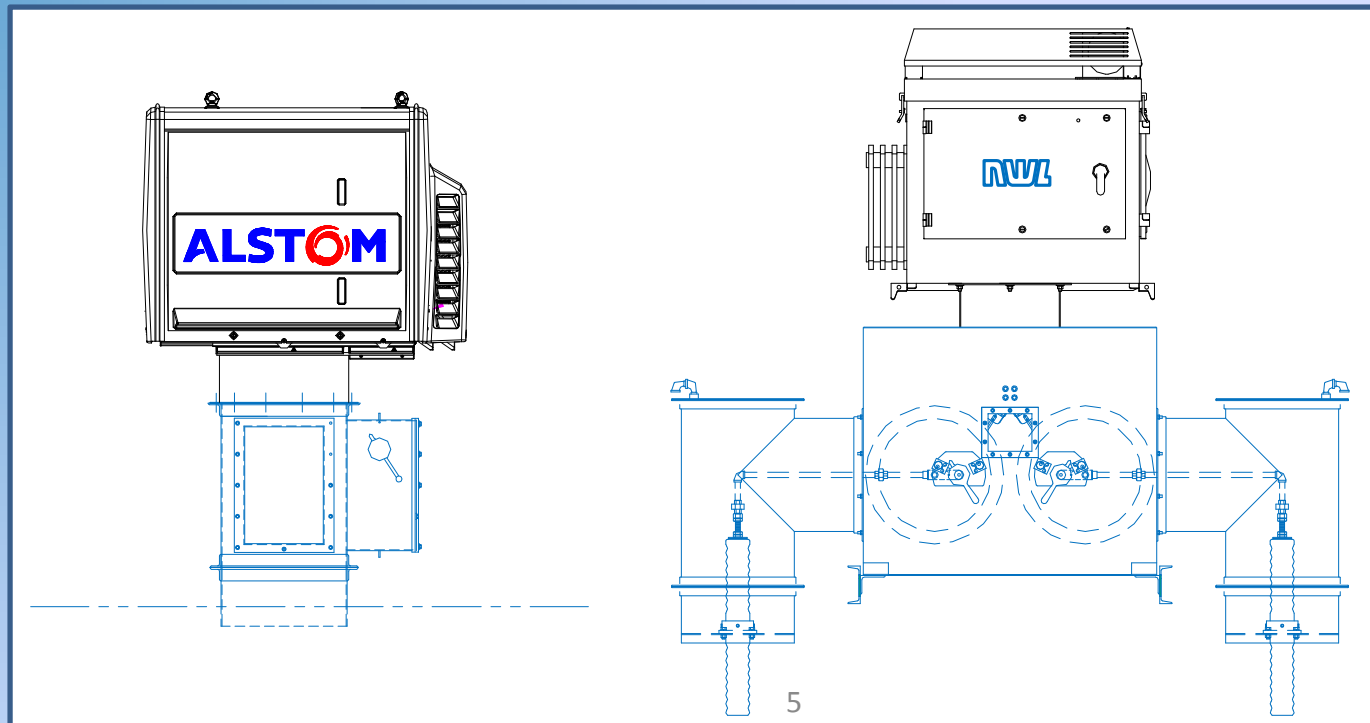

Rebuilding / Converting

- In – Kind Rebuild
- Conversion to Intermediate-Spaced Electrodes
- Conversion to Wide-Spaced Electrodes

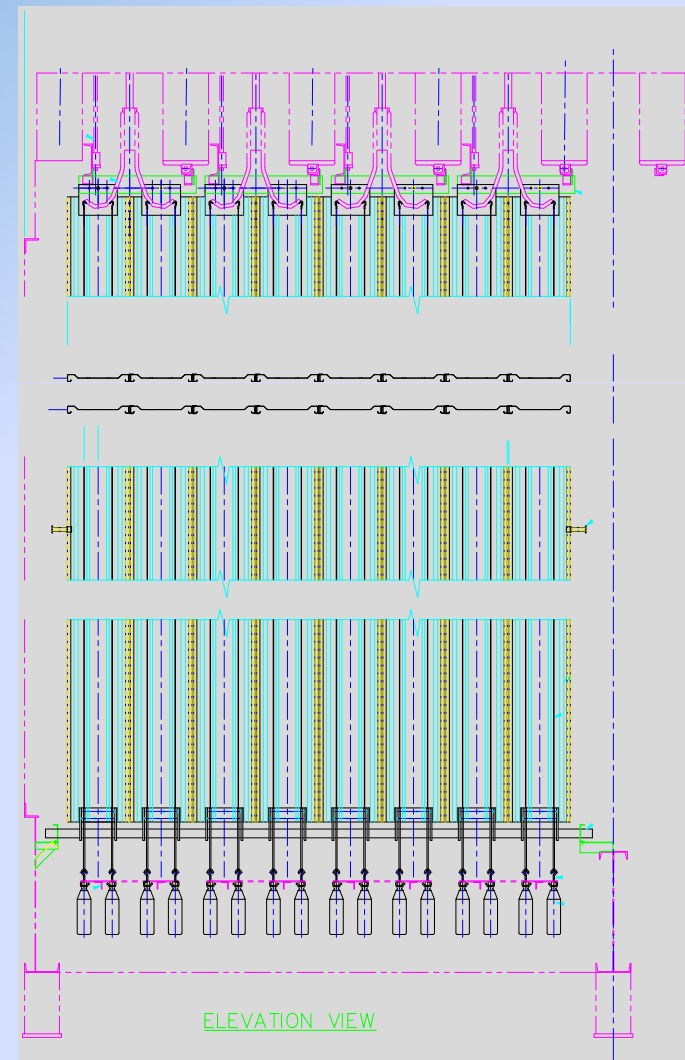

Rebuilding / Converting

- In – Kind Rebuild
- Conversion to Intermediate-Spaced Electrodes
- Conversion to Wide-Spaced Electrodes

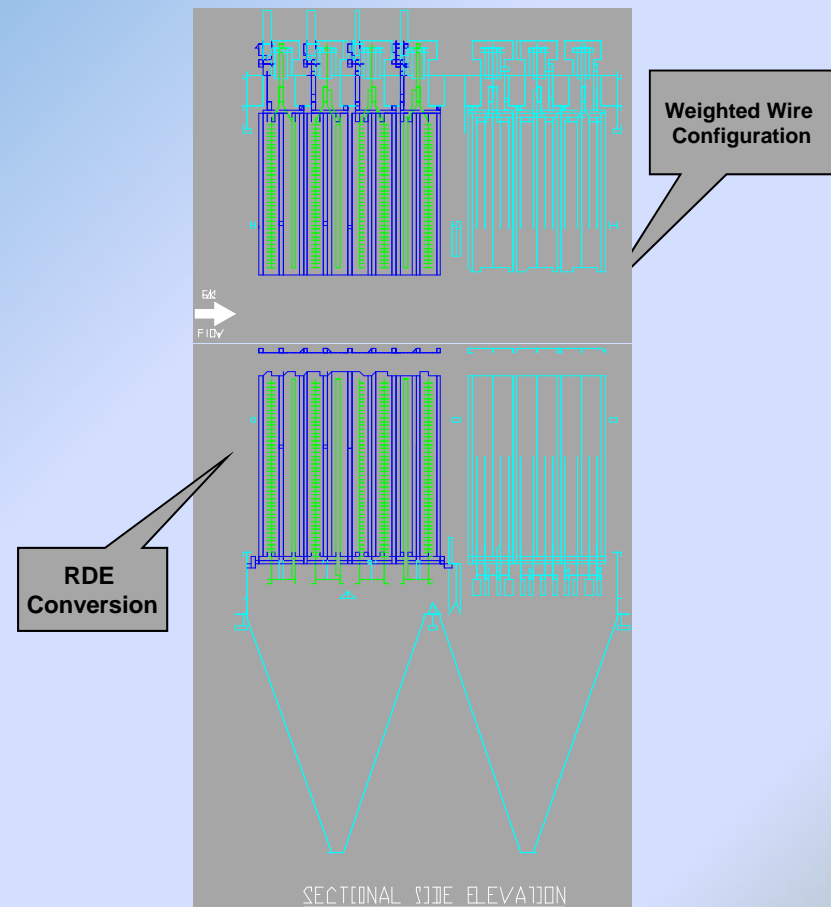

Rebuilding / Converting

- Conversion to Wide-Spaced Electrodes
 - Conventional
 - High Energy

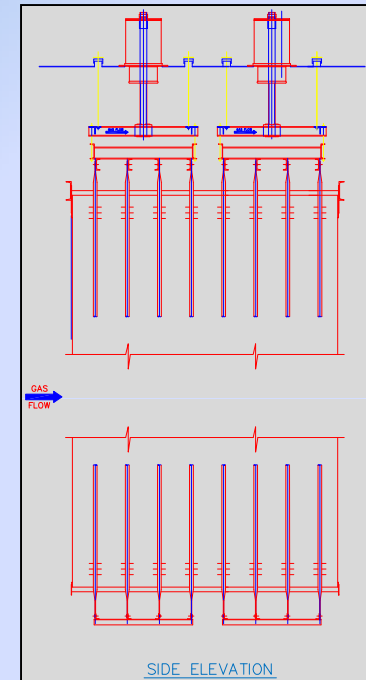
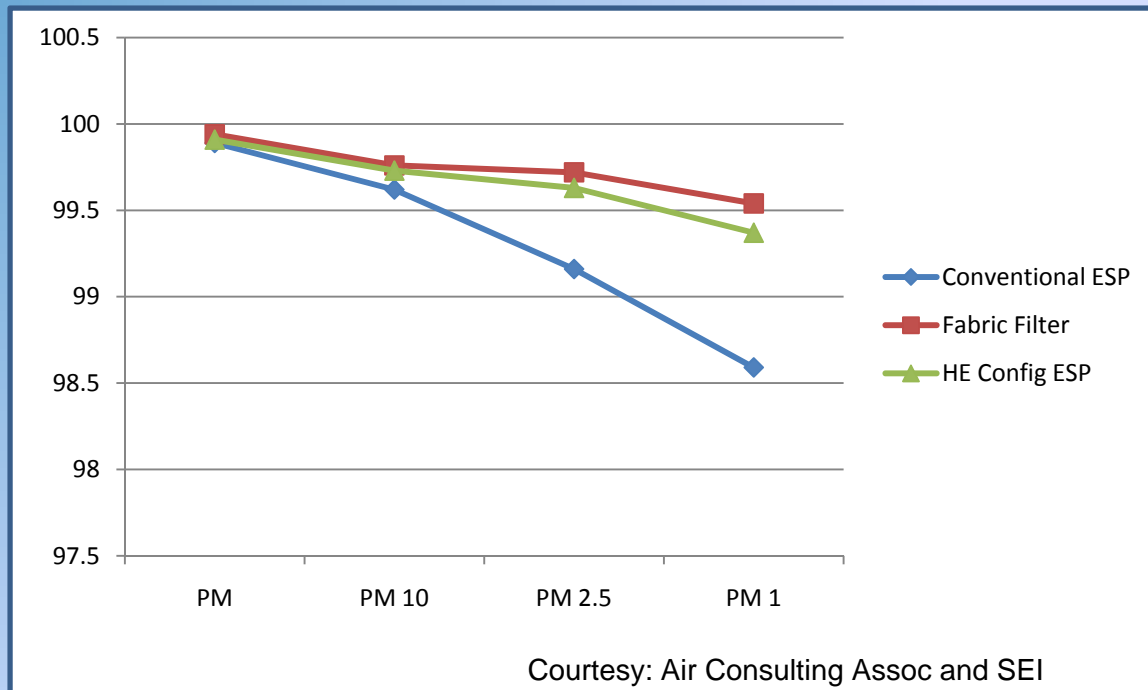

Flow Improvement

- Improve Flow Uniformity
- Improve Temperature Uniformity
- Reduce Reentrainment
- Reduce Sweepage

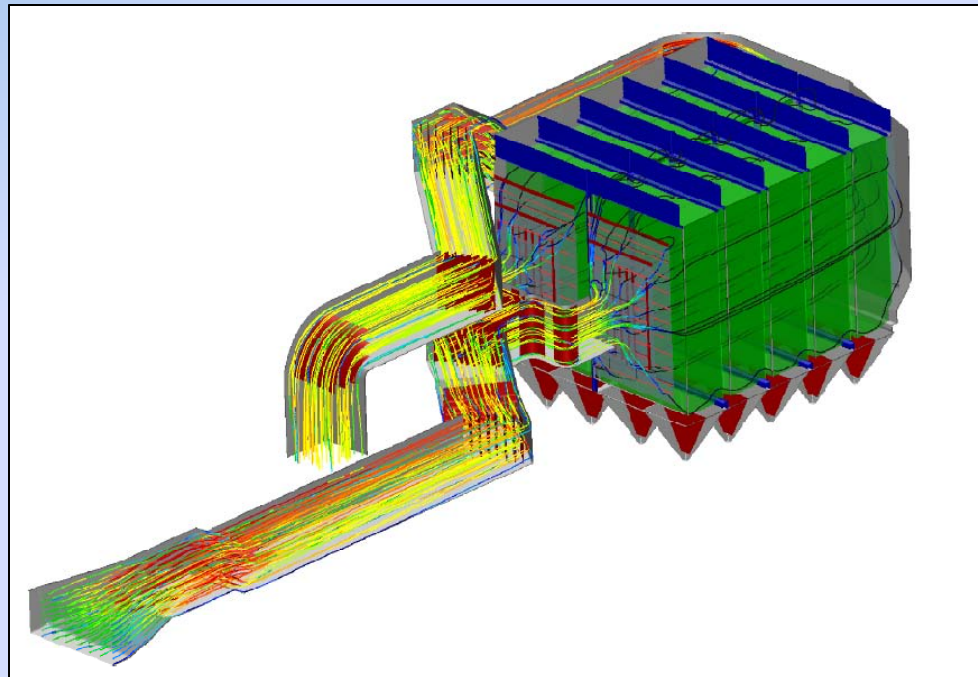

Gas Conditioning

- SO_3
- NH_3
- Trona
- Sodium (Hotside)

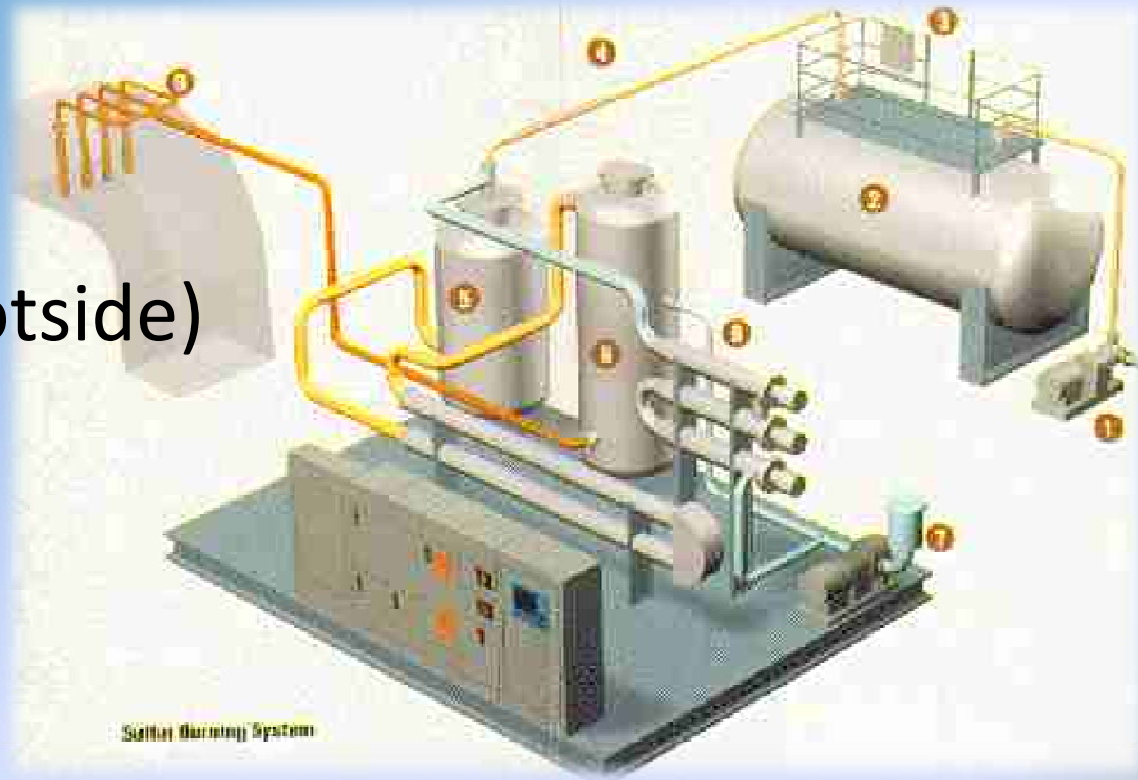

Collecting Area Expansion

- Taller
- Deeper
- Wider



Relative Benefits of Various Approaches

| Activity | Relative Cost | Expected Improvement |
|---------------------------|---------------|----------------------|
| Power Sectionalization | Medium | Low to Significant |
| Rapping Sectionalization | Medium | Low |
| Repowering | Medium | Significant |
| Rebuilding / Converting | High | Significant |
| Flow Improvement | Medium | Significant |
| Gas Conditioning | Medium | Significant |
| Collecting Area Expansion | Highest | Most Improvement |

Relative Improvement Due to Expansion Types

| Case Number | Expansion | SCA | Emissions Lb/MMBTU |
|-------------|--------------------------|--------------------------------|--------------------|
| Base Case | N/A | 186 ft ² /1000 acfm | 0.030 |
| Taller | Expand from 30' to 36' | 224 ft ² /1000 acfm | 0.025 |
| Wider | Expand from 162' to 200' | 230 ft ² /1000 acfm | 0.024 |
| Deeper | Add 1 Field | 232 ft ² /1000 acfm | 0.017 |

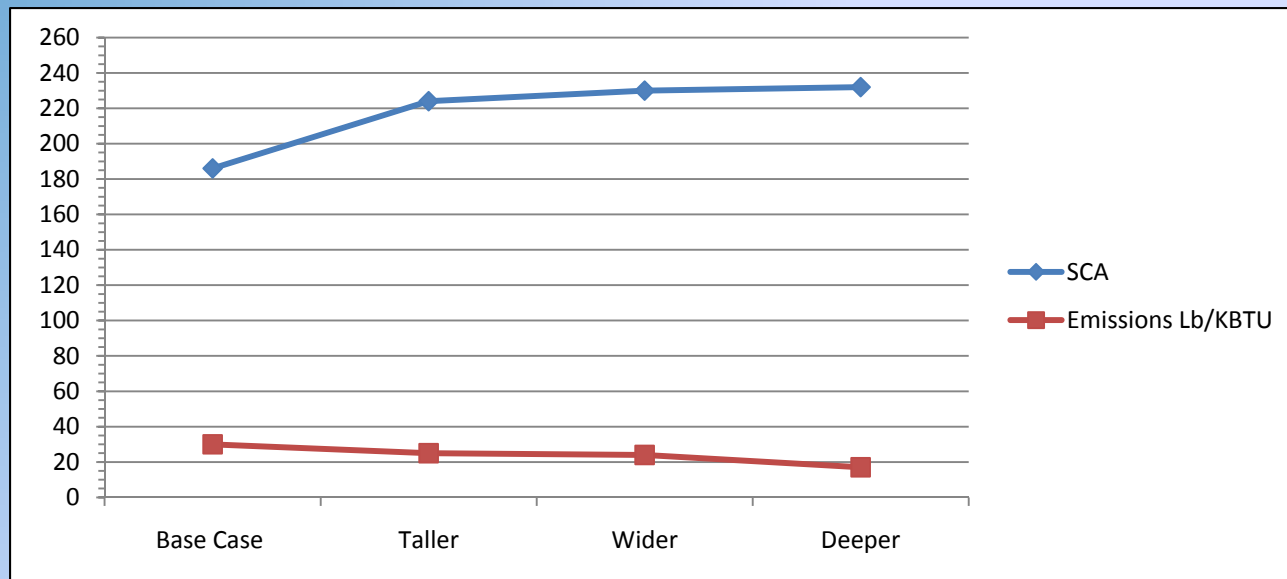

Three Cases:

| Case Number | Modification | Expansion |
|-------------|-------------------------|------------------|
| Case 1 | Gas Conditioning, etc | Additional Depth |
| Case 2 | Rearrange Flow, Rebuild | Additional Depth |
| Case 3 | None | Additional Depth |

Case 1

| Case Description | SCA | Mass Emissions | Opacity |
|----------------------|--------------------------------|----------------|---------|
| Base Case | 211 ft ² /1000 acfm | 0.088 Lb/MMBtu | 13.2 % |
| Add Gas Conditioning | 211 ft ² /1000 acfm | 0.062 Lb/MMBtu | 8.1 % |
| Add One 16.7' Field | 282 ft ² /1000 acfm | 0.012 Lb/MMBtu | 2.0 % |

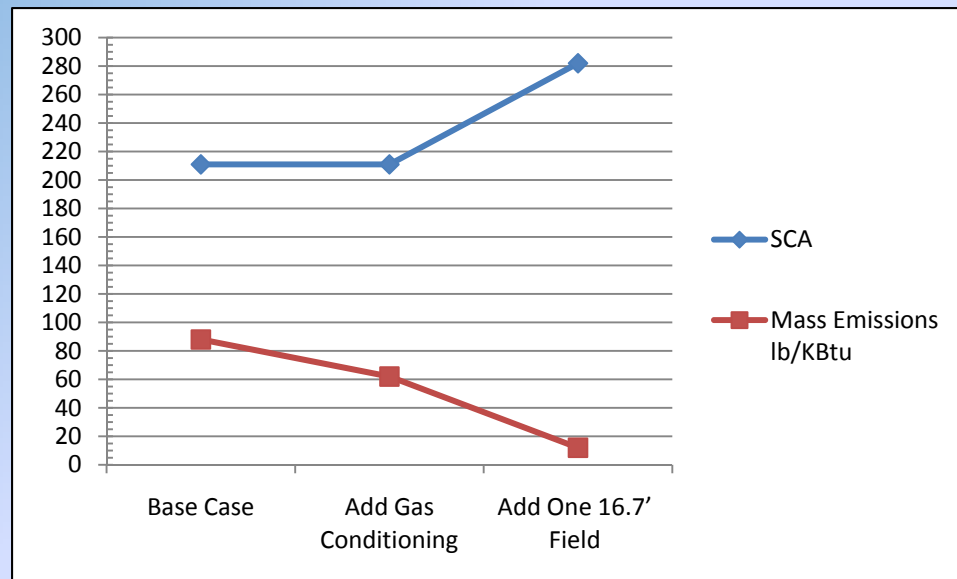

Case 2

| Case Description | SCA | Mass Emissions | Opacity |
|--|--------------------------------|----------------|---------|
| Base Case | 370 ft ² /1000 acfm | 0.016 Lb/MMBtu | 9.7 % |
| Total Flow Through One Casing | 185 ft ² /1000 acfm | 0.024 Lb/MMBtu | 16.6 % |
| Total Flow Through One Casing and One New Casing | 352 ft ² /1000 acfm | 0.003 Lb/MMBtu | 1.6 % |
| Total Flow Through One Casing and One New Casing | 370 ft ² /1000 acfm | 0.003 Lb/MMBtu | 1.6 % |
| All Four Casings in Service | 704 ft ² /1000 acfm | 0.001 Lb/MMBtu | 1.1 % |

Case 2 Existing Configuration



Lower ESP

Upper ESP

(#)

Case 2 – Short Outage Options

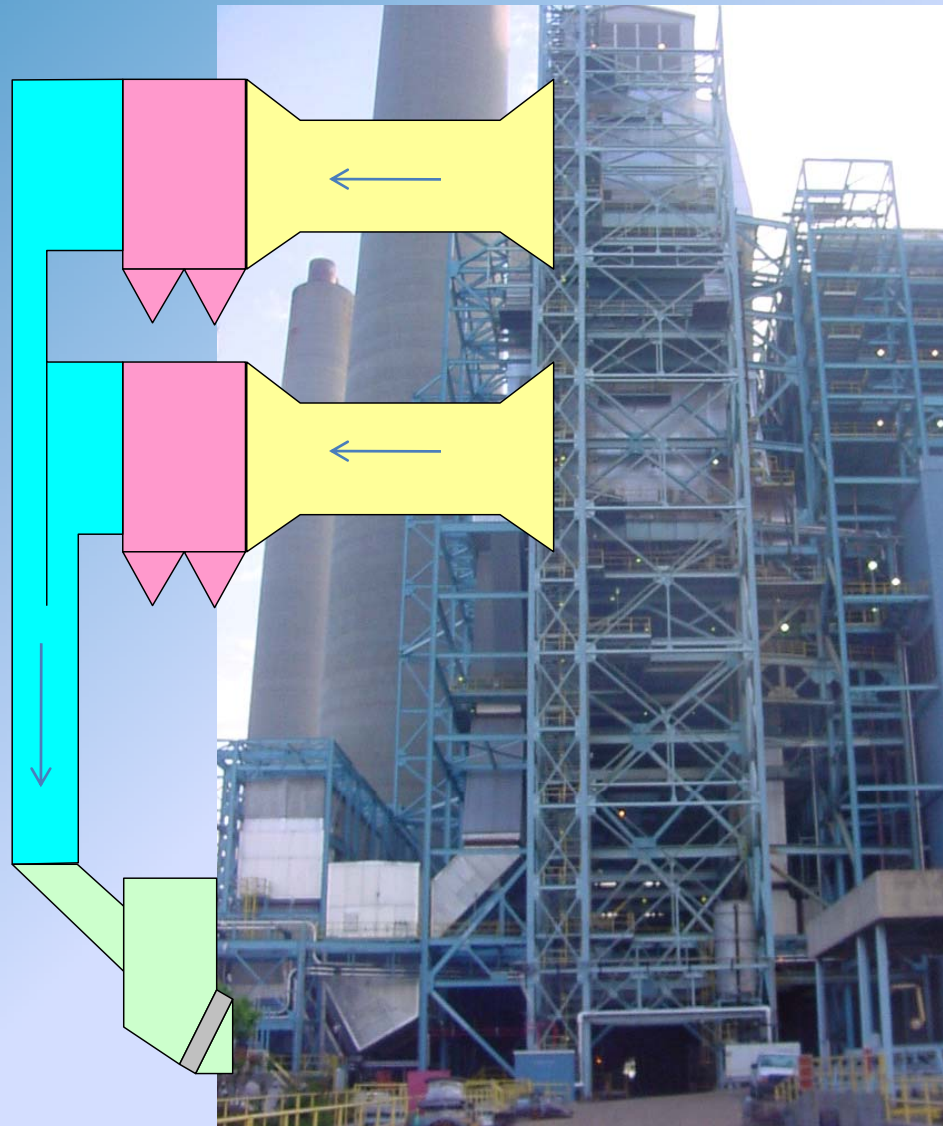

Case 3

| Case Description | SCA | Mass Emissions | Opacity |
|--|--------------------------------|----------------|---------|
| Base Case | 370 ft ² /1000 acfm | 0.016 Lb/MMBtu | 9.7 % |
| Add 5 Fields, 45' Tall at Ground Level | 690 ft ² /1000 acfm | 0.014 Lb/MMBtu | 4.7 % |
| Add 6 Fields, 45' Tall at Ground Level | 828 ft ² /1000 acfm | 0.003 Lb/MMBtu | 1.2 % |
| Add 6 Fields, 36' Tall at Ground Level | 662 ft ² /1000 acfm | 0.005 Lb/MMBtu | 2.0 % |

Relative Casing Cross Sections

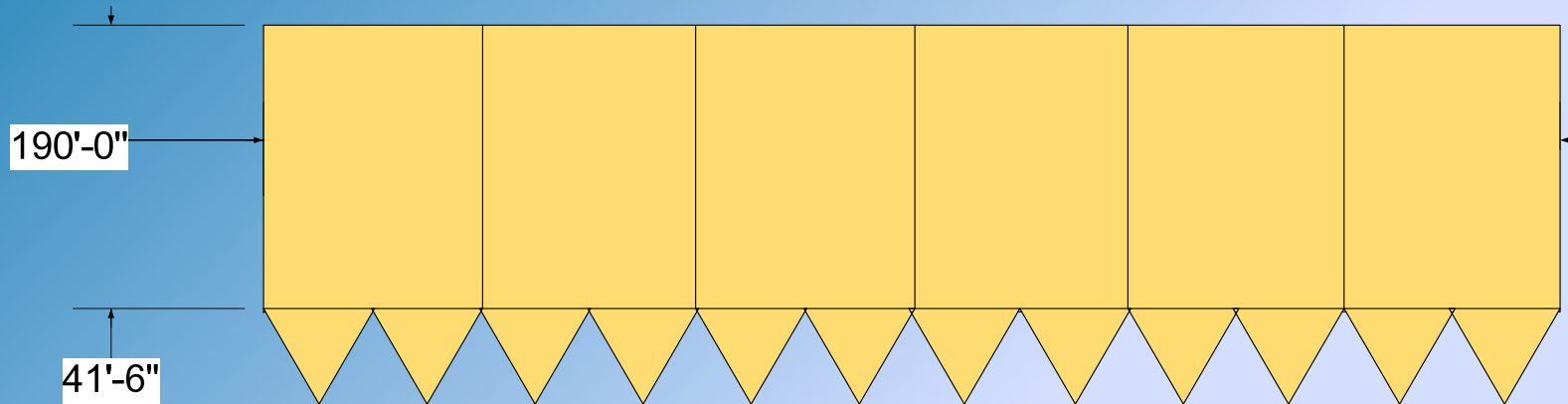

Elevation Transverse - Existing Buell Casing

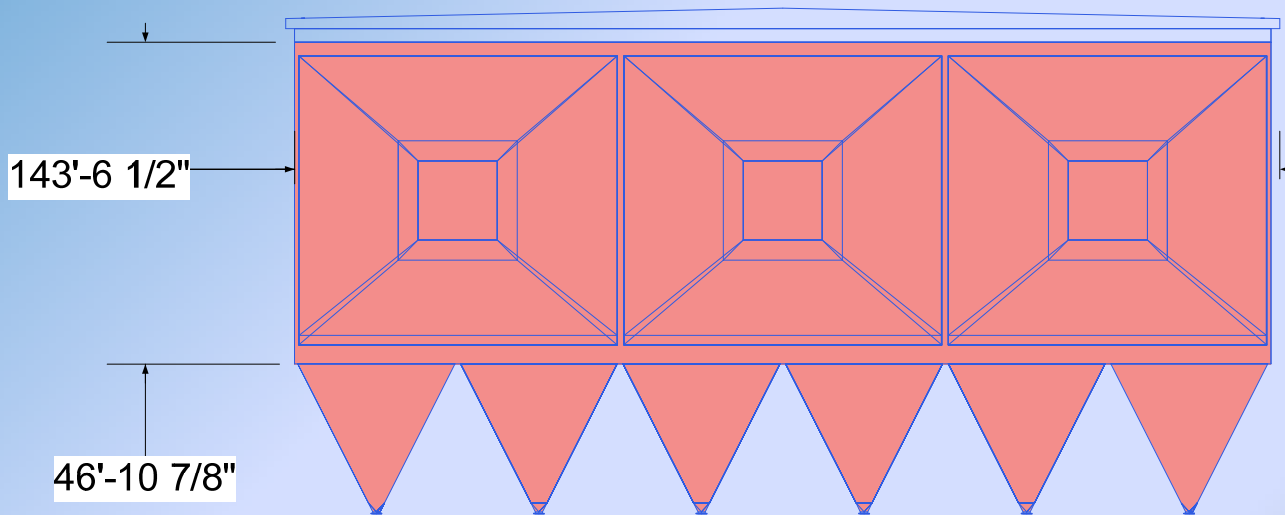

Elevation Transverse - Existing Flakt Casing,
Options 1,2,&3
(#)

Relative Casing Cross Sections

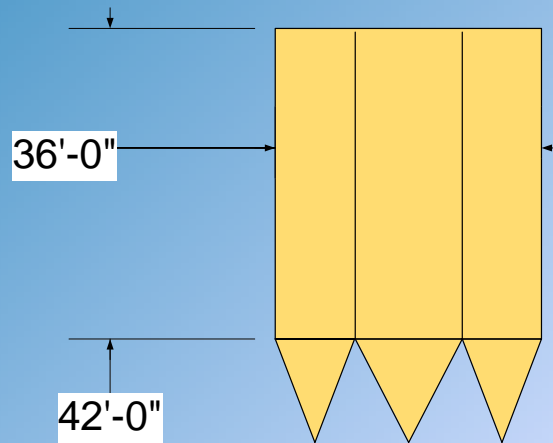

Elevation Longitudinal - Existing Buell Casing

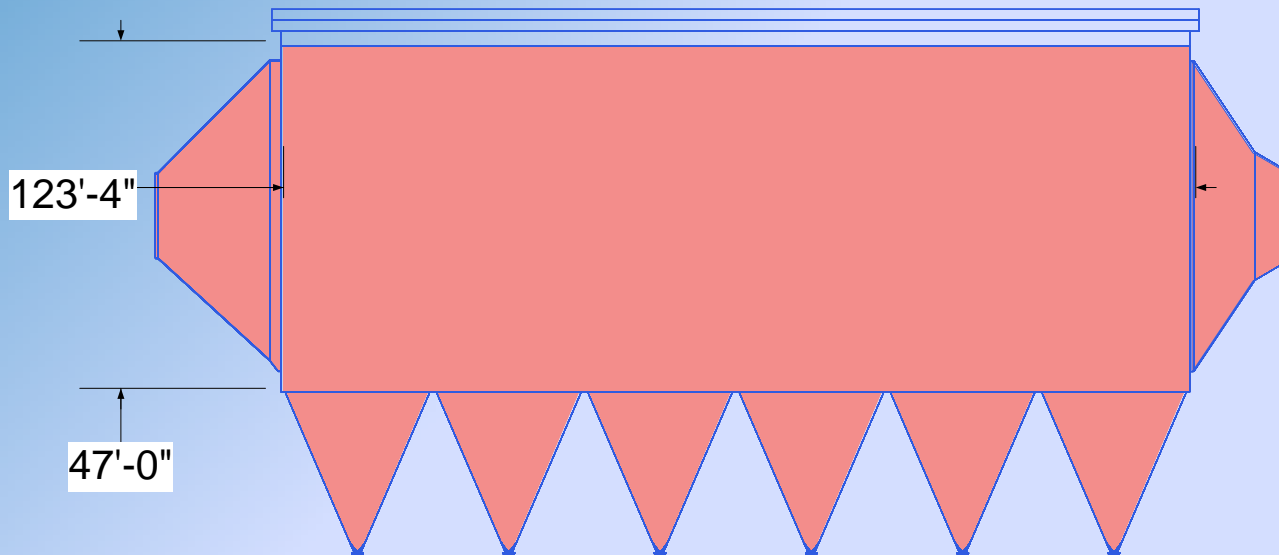

Elevation Longitudinal - Existing Flakt Casing,
Option 3

What SCA is required to meet the EGU MACT in these cases?

| Case Number | Existing Outlet Mass Emissions | Existing SCA | Needed SCA to Achieve 0.013 Lb/MMBTU |
|-------------|--------------------------------|---|---|
| Case 1 | 0.081 lb/MMBtu | 375 ft ² /1000 acfm No Gas Conditioning | 501 ft ² /1000 acfm With SO ₃ Gas Conditioning |
| Case 2 | 0.081 lb/MMBtu | 375 ft ² /1000 acfm No Gas Conditioning | 563 ft ² /1000 acfm No Gas Conditioning |

Summary

- Improving performance of aging ESPs is possible at two levels; In space and expansion of space.
- In space improvements are generally possible through upgrades of existing equipment or conversion to newer technology.
- Expansion of space is possible depending on various factors such as ground area availability, ducting, and impact to other equipment such as ID fans.
- Expansion of space can be done in three ways, each having different cost and performance benefits.